

# MANCHESTER II

SCONCE™

---



CRENSHAW

---

# MANCHESTER II

SCONCE™



13 1/4" W · 38" H · 17" EXT

≈ 50 lbs.

BRASS

(1) INTEGRATED LED  
1 CIRCUIT

NRTL: DRY, DAMP, WET

*\*captured in Antique Bronze  
patina / white opal glass*

*Designs are the sole property  
of Crenshaw Lighting and  
may not be conveyed to third  
parties without express written  
consent.*

*Copyright © 2022 Crenshaw Lighting  
All Rights Reserved*

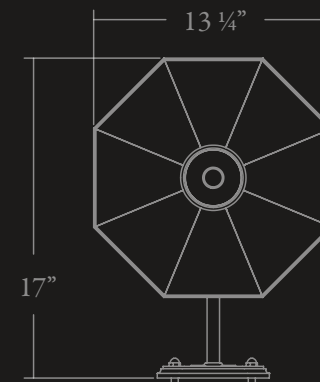

# MANCHESTER II

SCONCE™

---

POLISHED BRASS

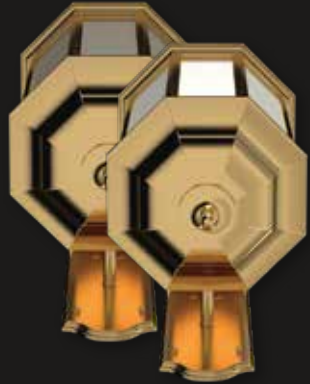

SATIN BRASS

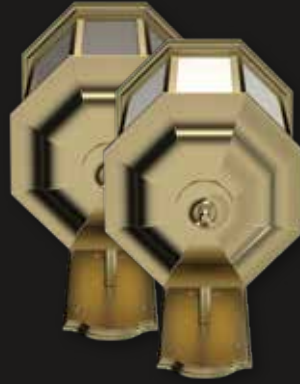

AGED BRASS

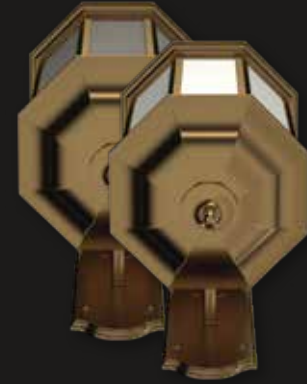

ANTIQUÉ BRONZE



OIL RUBBED BRONZE



# MANCHESTER II

SCONCE™

---

