

MILLS

LANTERN PENDANT™



CRENSHAW

MILLS

LANTERN PENDANT™

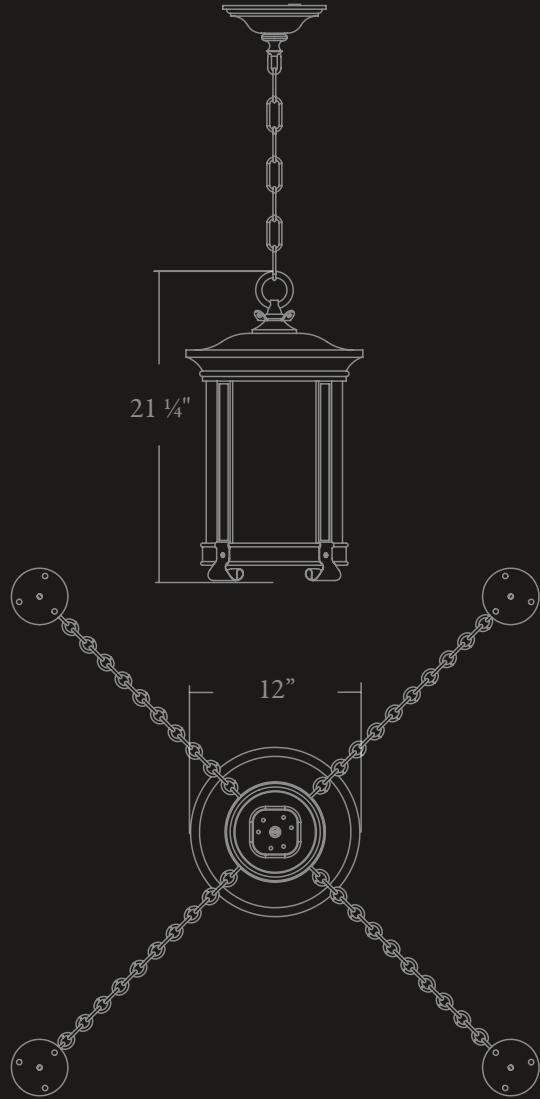

12" W · 21 ¼" H

≈ 30 lbs.

BRASS

(1) 60W A19
1 CIRCUIT

CHAIN SUSPENSION

NRTL: DRY, DAMP

**captured in Antique Bronze patina / white opal glass*

Designs are the sole property of Crenshaw Lighting and may not be conveyed to third parties without express written consent.

*Copyright © 2022 Crenshaw Lighting
All Rights Reserved*

All Crenshaw fixtures are NRTL listed unless otherwise noted. All fixtures are lab tested and certified to comply with ballast, driver, and component manufacturer warranty requirements.

MILLS
LANTERN PENDANT™

POLISHED BRASS



SATIN BRASS



AGED BRASS



ANTIQUÉ BRONZE



OIL RUBBED BRONZE



MILLS

LANTERN PENDANT™

