

PARK VIEW II

ARM SCONCE™



CRENSHAW

PARK VIEW

ARM SCONCE™

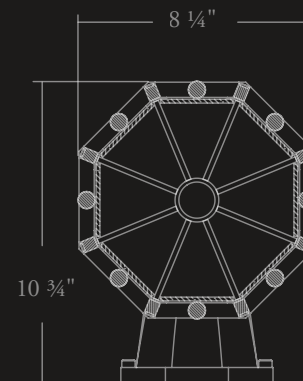
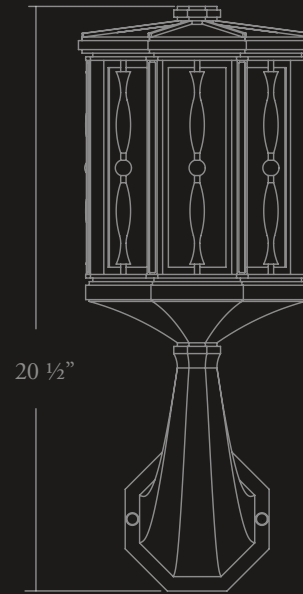

8 1/4" W · 20 1/2" H · 10 3/4" EXT

≈ 40 lbs.

BRASS

(1) 100W A19
1 CIRCUIT

NRTL: DRY, DAMP, WET

**captured in Antique Bronze
patina / white opal glass*

*Designs are the sole property
of Crenshaw Lighting and
may not be conveyed to third
parties without express written
consent.*

*Copyright © 2022 Crenshaw Lighting
All Rights Reserved*

PARK VIEW

ARM SCONCE™

POLISHED BRASS



SATIN BRASS



AGED BRASS



ANTIQUÉ BRONZE



OIL RUBBED BRONZE



PARK VIEW II

ARM SCONCE™

