

ROCK CREEK

SCONCE™



CRENSHAW

ROCK CREEK

SCONCE™

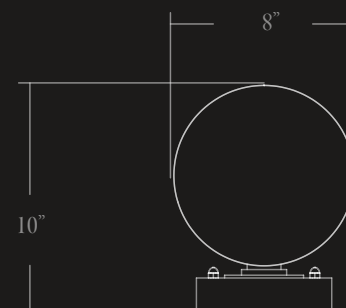
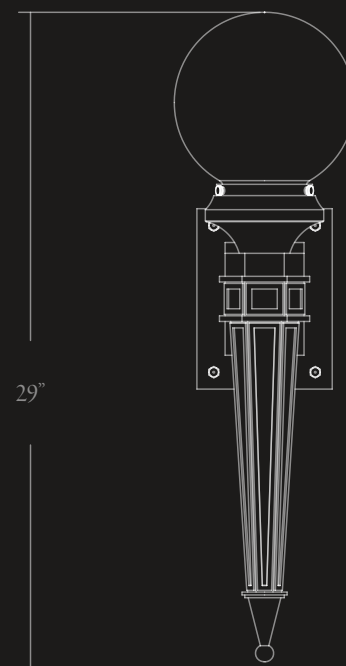

8" W · 29" H · 10" EXT

≈ 20 lbs.

BRASS

(1) 60W A19
1 CIRCUIT

NRTL: DRY, DAMP, WET

**captured in Antique Bronze
patina / white opal glass*

*Designs are the sole property
of Crenshaw Lighting and
may not be conveyed to third
parties without express written
consent.*

*Copyright © 2022 Crenshaw Lighting
All Rights Reserved*

ROCK CREEK

SCONCE™

POLISHED BRASS



SATIN BRASS

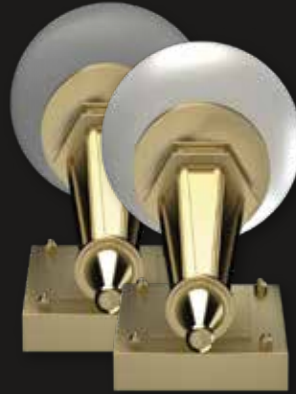

AGED BRASS



ANTIQUÉ BRONZE



OIL RUBBED BRONZE



ROCK CREEK

SCONCE™

